



ST. ANNE'S COLLEGE OF ENGINEERING AND TECHNOLOGY
(Approved by AICTE, New Delhi. Affiliated to Anna University, Chennai)
ANGUCHETTYPALAYAM, PANRUTI – 607 106

DEPARTMENT OF ELECTRICAL AND ELECTRONICS ENGINEERING

EE3601 PROTECTION OF SWITCHGEAR

UNIT I

Introduction

PROTECTION SCHEMES

- The protective system is very much essential for an electrical power system, which is used to isolate the faulty equipment from the system and protect the other equipments as quickly as possible.
- In case of short circuits or faults, the need for a protective system is felt, if not isolated it would totally damage the power system.
- Each part of the power system is protected.
- The protective systems include circuit breakers and protective relays, to isolate the faulty section of the power system from the healthy ones.

Principles of the Protective System

- The function of a protective relay is to sense the abnormal conditions in the power system and gives an alarm or isolates that part from the healthy system.
- It minimizes the damage to the equipment and interruptions to the service when electrical failure occurs.
- The relays are compact, self-contained devices which respond to abnormal conditions. Whenever a fault occurs, the relay contacts get closed which intern closes the trip circuit of a circuit breaker.
- Primary winding of a C.T which is connected in series with the line to be protected.

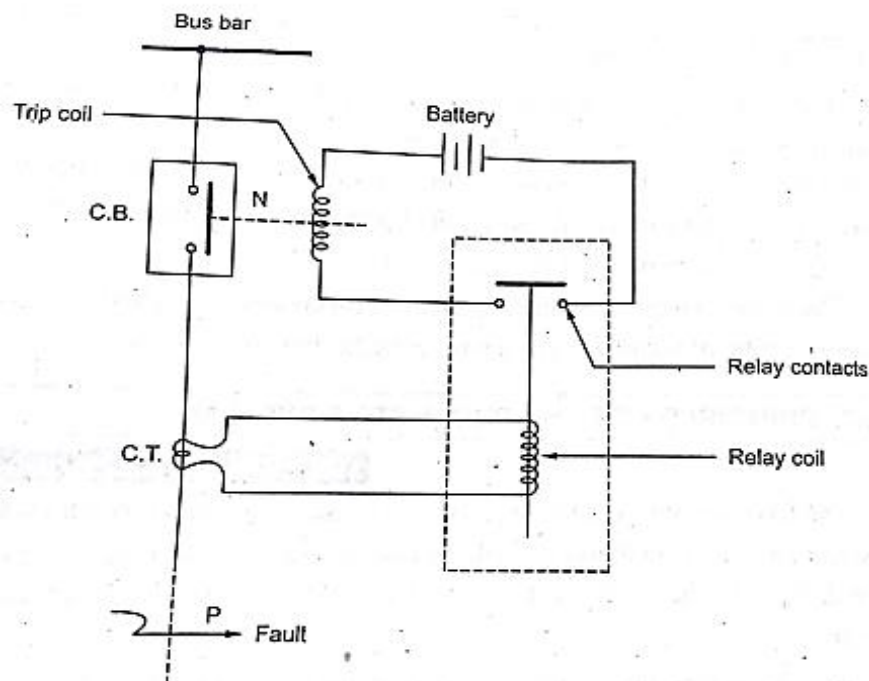

(ii) The secondary winding of C.T and relay operating coil.

(iii) Tripping circuit which may be A.C or D.C. It consists of a source of supply, the trip coil of the C.B and the relay stationary contacts.

Essential qualities of protective relaying

A well designed and effective relaying should have the following essential qualities

Speed

The relay system should disconnect the faulty section as quickly as possible for the following reasons.

- (i) Improves the stability
- (ii) Decreases the amount of damage caused
- (iii) Decreases the possibility of development of one type of fault into other more severe type.

Selectivity

It is the ability of the protective system to determine the point at which the fault occurs and disconnect the faulty part without disturbing the rest of the system.

Sensitivity

It is the ability of the relay system to operate with low value of actuating quantity. The relay should be sensitive to operate when the fault current exceeds the pickup value and should not operate when the fault current is less than pickup value.

Sensitivity factor ($K_s = I_s / I_o$)

Reliability

It is the ability of the relay system to operate under the pre-determined conditions.

Simplicity

The relaying system should be simple so that it can be easily maintained. It is closely related with the reliability.

Economy

The most important factor in the choice of a particular protection scheme is the economic aspect. As a rule, the protection cost should not be more than 5% of the total cost.

FUNCTIONS OF PROTECTIVE RELAYING

- The perfect removal of the component which is behaving abnormally by closing the trip circuit of circuit breaker or to sound an alarm.
- To disconnect the abnormally operating part as to avoid the damage to rest of the system.
- To prevent the subsequent faults by disconnecting the abnormally operating part.
- To disconnect the faulty part as quickly as possible so as to minimize the damage to the faulty part itself.
- To improve the system performance, stability, reliability and service continuity.

CAUSES OF A FAULT OR SHORT CIRCUIT

- Over voltage due to switching
- Over voltage due to the direct and indirect lightning strokes
- Bridging of conductors by birds
- Breakdown of insulation due to less dielectric strength
- Mechanical damage to the equipments

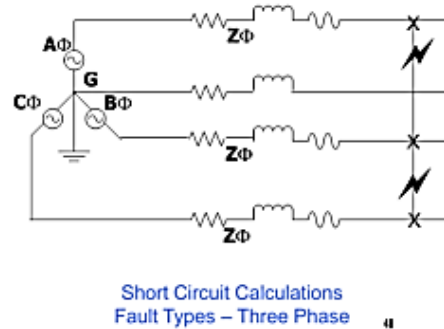
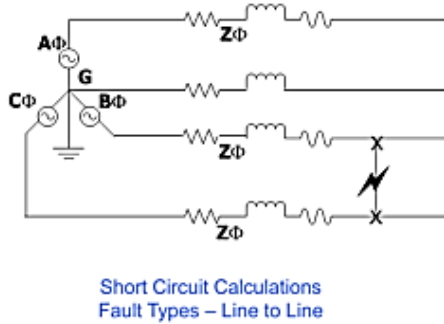
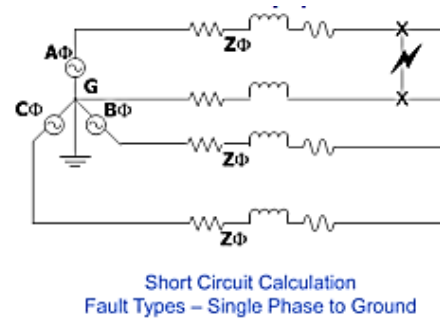
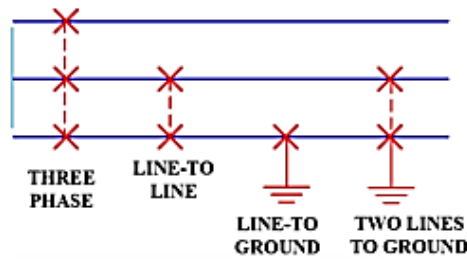

CONSEQUENCES OF FAULTS/EFFECT OF FAULTS

- A great reduction in line voltage over a major part of the power system which may lead to the breakdown of electrical supply to the consumer and may produce wastage in production
- Damage to other apparatus in the system due to overheating and due to abnormal mechanical forces setup.
- Damage caused to the elements of the system by the electrical arc which almost accompanies the short circuit.
- The stability of the power system is disturbed which may lead to a complete shutdown of the power system.
- Due to reduction voltage, currents drawn by motors are abnormally high. This may result into loss of industrial production.

Fault current component using symmetrical components

When the load is unbalanced, the analysis normal techniques becomes difficult.

- A balanced system of 3-phase currents having positive phase are called positive sequence components.
- A balanced system of 3-phase currents having opposite or negative phase sequence are called negative sequence components.
- A system of three currents equal in magnitude and having zero displacement are called zero sequence components.

The positive, negative and zero phase sequence components are called the symmetrical components of the original unbalanced system.

Illustration

- The positive, negative and zero phase sequence currents separately form balanced system of currents. Hence, they are called symmetrical components of the unbalanced system.
- This theory equally applies to 3-phase currents and voltages both phase and line values.
- The symmetrical components do not exist separately. They are only mathematical components of unbalanced current or voltages which actually flow in the system.
- In a balanced 3-phase system, negative and zero phase currents are zero.

ZONES OF PROTECTION

- In a protective relaying scheme, it is a usual practice to divide the entire system into several protection scheme.
- When a fault occurs in a given zone, then only the circuit breakers within that zone will be opened.
- This will isolate only the fault part, leaving the healthy circuit intact.
- A protective zone is the separate zone which is established around each system element.
- The significant of such a protective zone is that any fault occurring within a given zone will cause the tripping of relays which causes opening of all the circuit breakers located with in that zone.
 - (i) Generators
 - (ii) Low tension switchgear (LT)
 - (iii) Transformers
 - (iv) High-tension switchgear (HT)
 - (v) Transmission lines
- The boundaries of protective zone are decided by the locations of CT.
- The overlapping is done to ensure complete safety of each and every element of the system.
- The zone which is not protected is called dead spot.
- If there are no overlaps, then dead spot may exist, means the circuit breakers lying within the zone may not open even if the fault occurs.
- This causes damage to the healthy system.
- The probability of the failures in the overlapped region is very low and therefore the opening of too many C.B. will also be infrequent.
- Each zone has certain protective scheme and each protective scheme

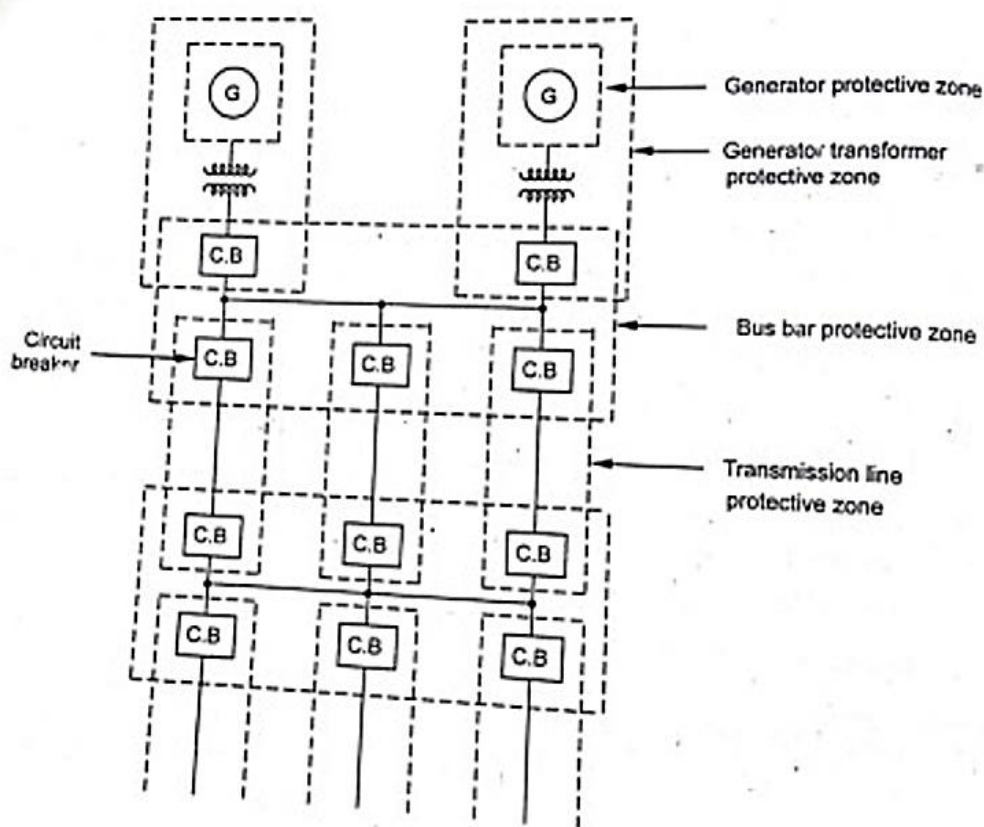

Primary and Back-up protection

- Primary protection is the main protection provided for protecting the power system elements from all types of faults.
- If the primary protection fails, the back-up protection comes into action and removes the faulty part from the healthy system.

- The backup protection is provided as the main protection can fail due to many reasons like,
 - Failure in C.B
 - Failure in protective relay
 - Failure in d.c tripping voltage
 - Loss of voltage or current supply to the relay
 - Thus, if there is no backup protection and the main protection fails then there is possibility of severe damage to the system.
 - From the cost and economy point of view, the backup protection is employed only for the protection against S.C and not for any other abnormal conditions.

Concept of back-up relay

- The main requirement of backup relaying is that it must operate with minimum time delay so that the primary relaying is given a chance to operate.
- When fault occurs both type of relays starts relaying operation but primary is expected to trip first and backup will reset without having time to complete its relaying operation.

Methods of back up protection

- Relay back up protection
- Breaker back up protection
- Remote back up protection
- Centrally coordinated back-up protection

POWER SYSTEM EARTHING

- In power system grounding or earthing means connecting frame or electrical equipment (non-current carrying part) or some electrical part of the system (e.g. neutral point in a star connected system, one conductor of the secondary of the transformer) to earth.
- Grounding provides protection to the power system
- Earthing of electrical equipment ensures the safety of the persons handling the equipment.

Grounding or Earthing

- The process of connecting the metallic frame (i.e non-current carrying part) of electrical equipment or some electrical part of the system (e.g. neutral point in a star connected system, one conductor of the secondary of a transformer) to earth is called grounding or earthing.

Solid or Effective Grounding:

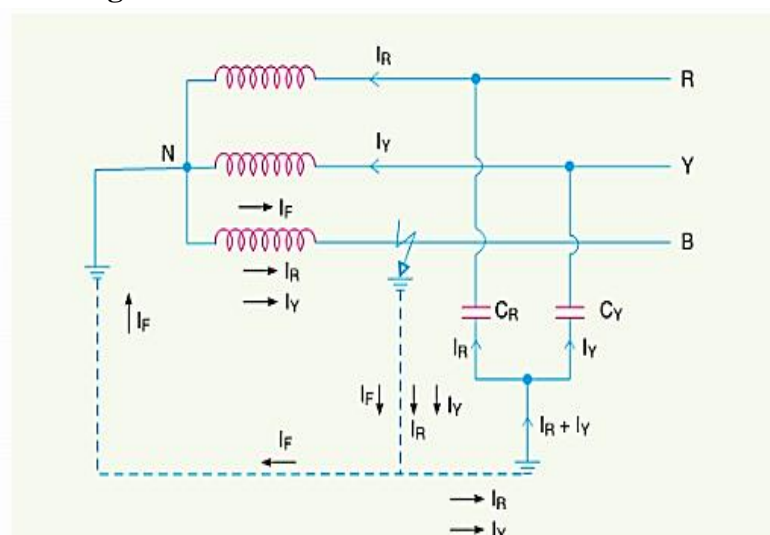

Resistance grounding

- In order to limit the magnitude of earth fault current, it is a common practice to connect the neutral point of a 3-phase system to earth through a resistor. This is called resistance grounding.

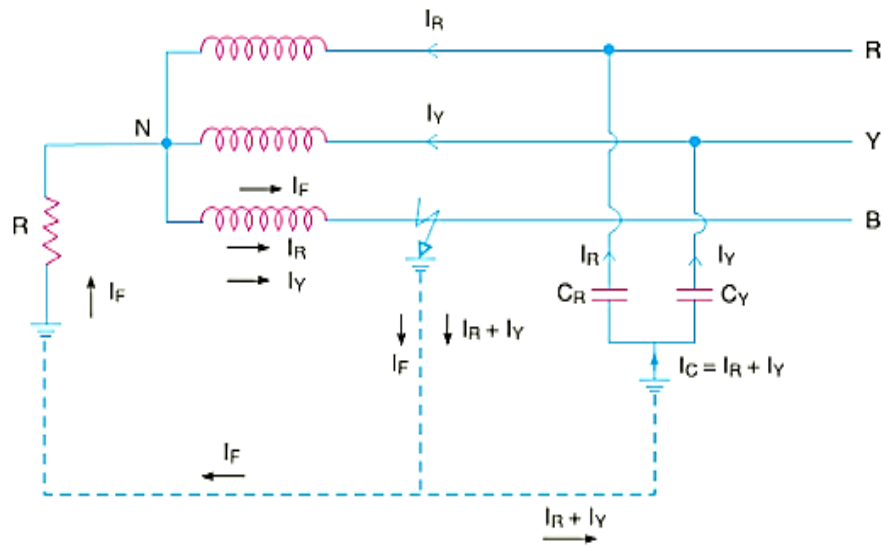

Disadvantages:

- The system neutral is displaced during earth faults, the equipment has to be insulated for higher voltages.
- This system is costlier than the solidly grounded system.
- A large amount of energy is produced in the earthing resistance during earth faults.

Applications:

- It is used on a system operating at voltages between 2.2kV and 33kV with power source capacity more than 5000kVA.



ST ANNES COLLEGE OF ENGINEERING AND TECHNOLOGY

DEPARTMENT OF ELECTRICAL AND ELECTRONICS ENGINEERING

EE8602 PROTECTION AND SWITCHGEAR

UNIT II

ELECTROMAGNETIC RELAYS

Introduction

Role of protective relay

- Energy provides the power to progress.
- In a power system consisting of generators, transformers, transmission and distribution circuits, it is usual that some failure may occur somewhere in the system.

Principles reasons for clear the fault

- If the fault is not cleared quickly, it may cause unnecessary interruption of service to customers.
- Quick recovery from fault limits the amount of damage to the equipment and prevents the effects of fault from spreading into the system.

Basic Relay

- Relays used in power system operate by virtue of the current and voltage supplied by current and voltage transformers connected in various combinations to the system element that is to be protected.
- Most of the relay in service on electric power system today are of electro-mechanical type. they work on the following two main operating principles:
 - (i) **Electromagnetic attraction**
 - (ii) **Electromagnetic induction**

Protective relaying

- The protective relaying is the monitoring process which senses the abnormal conditions in a part of the power system and gives an alarm or isolates that part from the healthy system.
- The relay detects the fault and supply information to the C.B which performs the function of circuit interruption.

Electromagnetic attraction relays

- Electromagnetic attraction relays operate by virtue of an armature being attracted to the poles of an electromagnet.
- Such relays may be **D.C.** or **A.C.** quantities.
- The important types of electromagnetic attraction relays are

Attracted armature type relay:

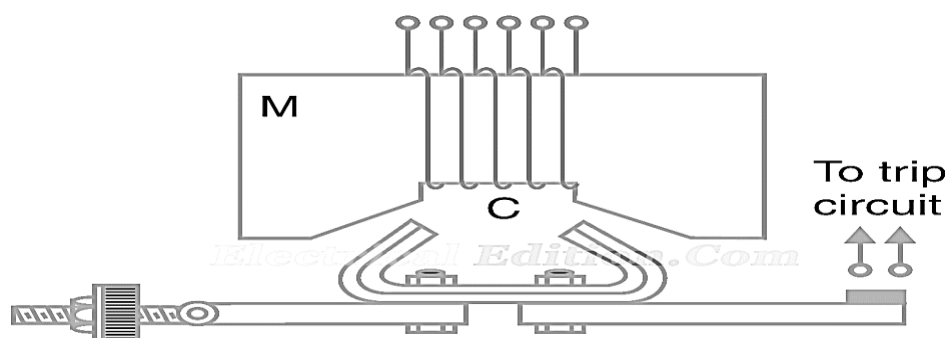

- Under normal operating conditions, the current through the coil C is such that counterweight holds the armature in the position shown.
- When a S.C occurs, the current through the relay coil increases sufficiently and the relay armature is attracted upwards.
- The minimum current at which the relay armature is attracted to close the trip circuit is called **pick up current**.

Solenoid type relay:

- It consists of a solenoid and movable iron plunger.
- Under normal condition, the current through coil holds the plunger by gravity or spring in the position.
- If fault occurs, the current through the relay coil becomes more than the pickup value, causing the plunger to be attracted to the solenoid.
- The upward movement of the plunger closes the trip circuit, thus operating the C.B. and disconnecting the faulty circuit.

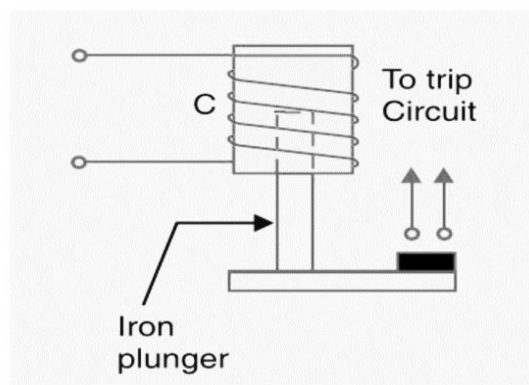

Solenoid type relay

Balanced beam type relay:

- It consists of an iron armature fastened to a balance beam.
- Under normal operating conditions, the current through the relay coil is such that the beam is held in the horizontal position by the spring.
- When a fault occurs, the current through the re-lay coil becomes greater than the pickup value and the beam is attracted to close the trip circuit.
- This causes the opening of the circuit breaker to isolate the faulty circuit.

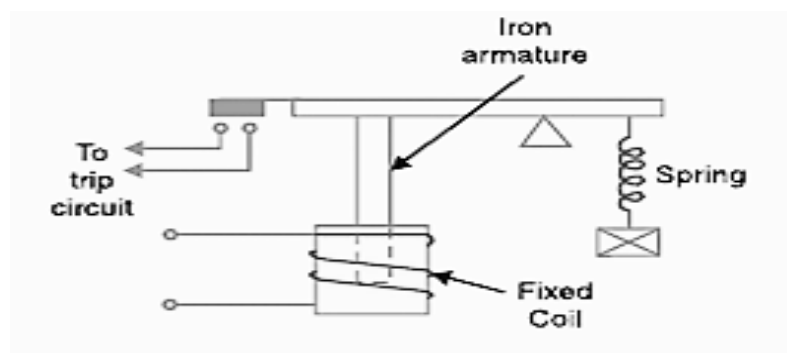

Induction Relays

- Electromagnetic induction relays operate on the principle of induction motor and are widely used for protective relaying purposes involving A.C. quantities.
- An induction relay essentially consists of a pivoted aluminium disc placed in two alternating magnetic fields of the same frequency but displaced in time and space.
- The torque is produced in the disc by the interaction of one of the magnetic fields with the currents induced in the disc by the other.

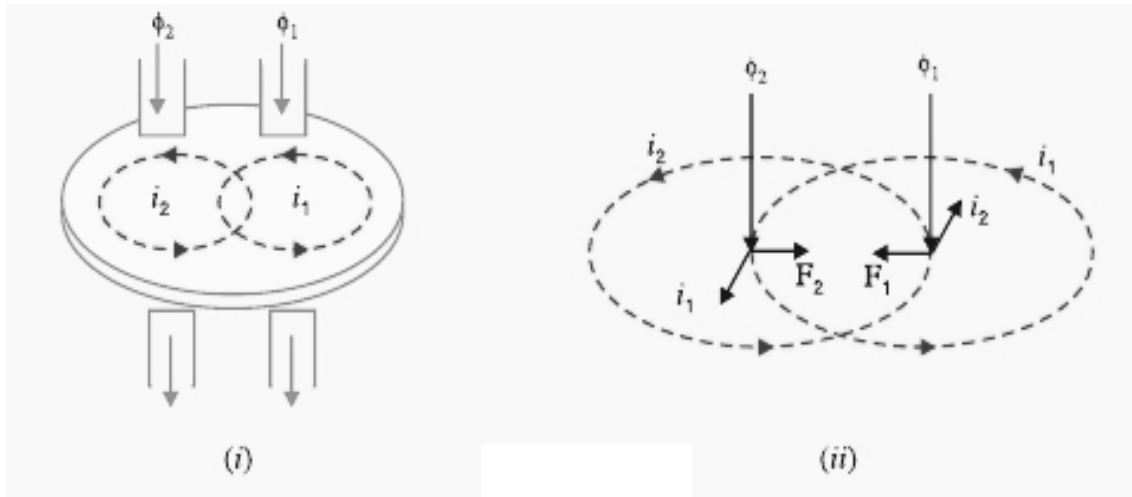

The following points may be noted:

- The maximum force will be produced when the two fluxes are 90 out of phase.
- The net force is the same at every instant.
- The direction of net force and hence the direction of motion of the disc depends upon which flux is leading.

The following three types of structures are commonly used for obtaining the phase difference in the fluxes and hence the operating torque in induction relays:

- shaded-pole structure
- watt-hour-meter or double winding structure
- induction cup structure

Important terms

(i) Pick-up current. It is the minimum current in the relay coil at which the relay starts to operate. So long as the current in the relay is less than the pick-up value, the relay does not operate and the breaker controlled by it remains in the closed position.

(ii) Current setting. It is often desirable to adjust the pick-up current to any required value. This is known as current setting and is usually achieved by the use of tapings on the relay operating coil.

Pick-up current = Rated secondary current of C.T. × Current setting

(iii) Plug-setting multiplier (P.S.M.): It is the ratio of fault current in relay coil to the pick-up current.

$$\text{P.S.M.} = \frac{\text{Fault current in relay coil}}{\text{Pick - up current}}$$

(iv) Time-setting multiplier. A relay is generally provided with control to adjust the time of operation. This adjustment is known as time-setting multiplier.

Functional Relay Types

- Most of the relays in service on power system today operate on the principle of electromagnetic attraction or electromagnetic induction.
- For example, a relay which recognizes over current in a circuit (i.e. current greater than that which can be tolerated) and initiates corrective measures would be termed as an over current relay irrespective of the relay design.
- Similarly, an overvoltage relay is one which recognizes over- voltage in a circuit and initiates the corrective measures.

- Induction type over current relays
- Induction type reverse power relays
- Distance relays
- Differential relays

Induction Type Over current Relay (non-directional)

- This type of relay works on the induction principle and initiates corrective measures when current in the circuit exceeds the predetermined value.

Constructional details

- It consists of a metallic (aluminium) disc which is free to rotate in between the poles of two electromagnets.
- The upper electromagnet has a primary and a secondary winding. The primary is connected to the secondary of a C.T. in the line to be protected and is tapped at intervals.

Operation:

- The driving torque on the aluminium disc is set up due to the induction principle. This torque is opposed by the restraining torque provided by the spring.
- Under normal operating conditions, restraining torque is greater than the driving torque produced by the relay coil current. Therefore, the aluminium disc remains stationary.
- If the current in the protected circuit exceeds the pre-set value, the driving torque becomes greater than the restraining torque.
- Consequently, the disc rotates and the moving contact bridges the fixed contacts when the disc has rotated through a pre-set angle.
- The trip circuit operates the circuit breaker which isolates the faulty section.

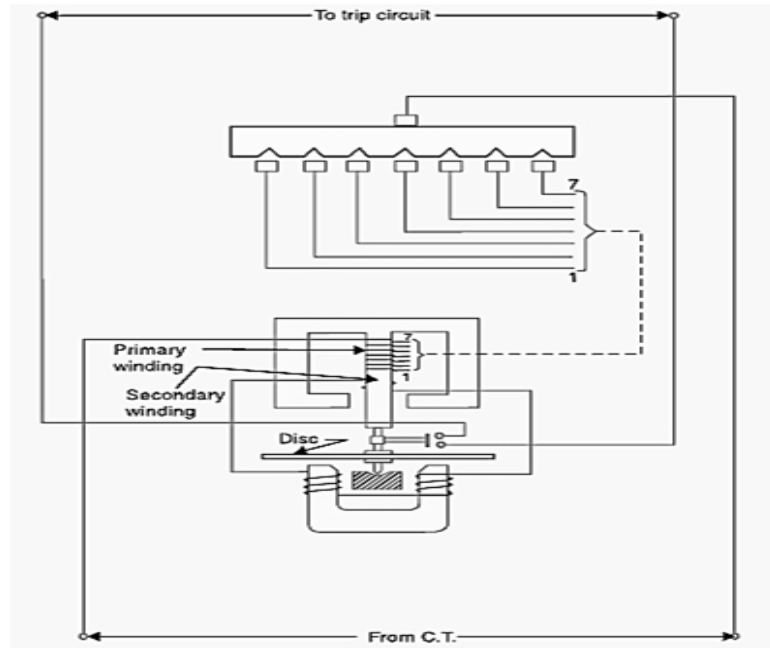

Induction Type Directional Power Relay

- This type of relay operates when power in the circuit flows in a specific direction.

Constructional details

- It consists of an aluminum disc which is free to rotate in between the poles of two electromagnets.
- The upper electromagnet carries a winding (called *potential coil*) on the central limb which is connected through a potential transformer (P.T.) to the circuit voltage source.
- The lower electromagnet has a separate winding (called *current coil*) connected to the secondary of C.T. in the line to be protected.

• Operation

- When the power in the circuit flows in the normal direction, the driving torque and the restraining torque (due to spring) help each other to turn away the moving contact from the fixed contacts.
- Consequently, the relay remains inoperative.

- However, the reversal of current in the circuit reverses the direction of driving torque on the disc.
- When the reversed driving torque is large enough, the disc rotates in the reverse direction and the moving contact closes the trip circuit. This causes the operation of the circuit breaker which disconnects the faulty section.

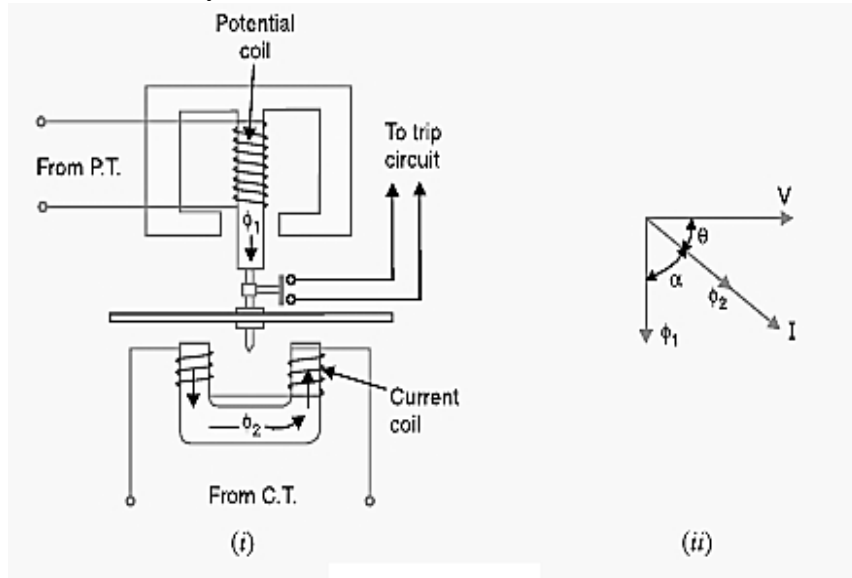

Distance relay

- **Distance relay** is non-unit type protection. It is high speed protection and is simple to apply.
- Distance protection is a widely used protective scheme for the protection of **high and extra high voltage transmission line**.
- It can be used in carrier aided distance schemes and in auto reclosing schemes.

Types of distance relays

- Depend on the ratio of V and I there are five types of distance relays.
 - Impedance relay
 - Reactance relay
 - Admittance relay(mho)
 - Ohm relay
 - Offset mho relay

Impedance relay

- In an impedance relay, the torque produced by a current element is opposed by the torque produced by a voltage element.
- The relay will operate when the ratio V/I is less than a pre-determined value.

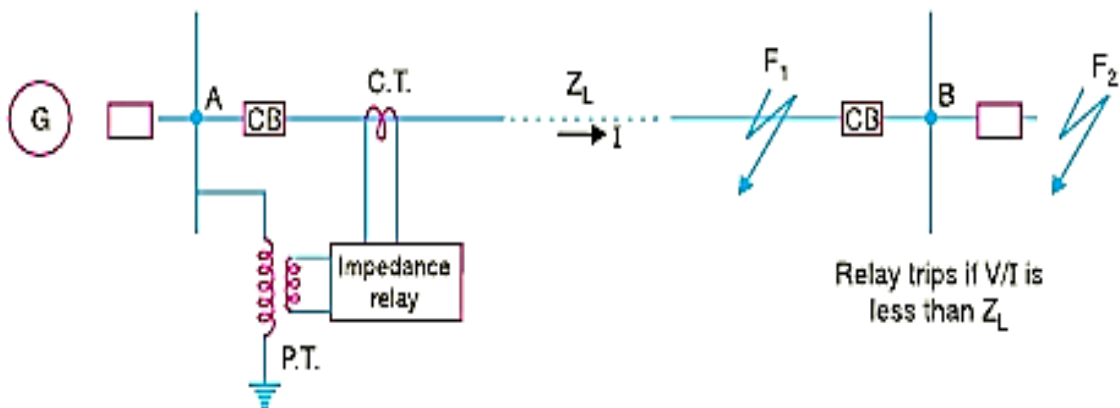

Types of impedance relay

- A distance or impedance relay is essentially an ohmmeter and operates whenever the impedance of the protected zone falls below a pre-determined value.
- There are two types of distance relays in use for the protection of power supply, namely;

(i) **Definite-distance relay** :which operates instantaneously for fault upto a pre-determined distance from the relay.

(ii) **Time-distance relay** in which the time of operation is proportional to the distance of fault from the relay point. A fault nearer to the relay will operate it earlier than a fault farther away from the relay.

Reactance relay

- A reactance relay measures the reactance of the line at the relay location, and is not affected by variations in resistance.
- Hence its performance remains unaffected by arc resistance during the occurrence of fault.
- In case fault on the protected line, the measured reactance is the reactance of the line between the relay location and the fault point.
- The current is the operating quantity, it produces flux in the upper, lower and right hand side poles.
- The right hand side pole is out of phase with the flux in the lower and upper poles because of secondary winding which is closed by a phase shifting circuit.
- The polarizing flux and right hand side pole flux interacts to produce the operating torque.
- The interaction of left hand side pole flux and the polarizing flux produces the restrain torque.

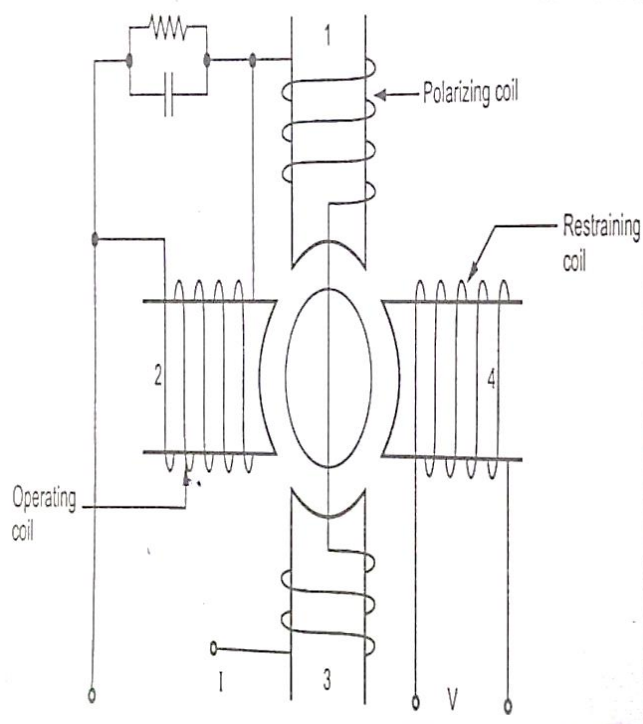

Differential Relay:

- Most of the relays discussed so far relied on excess of current for their operation. Such relays are less sensitive because they cannot make correct distinction between heavy load conditions and minor fault conditions.
- In order to overcome this difficulty, differential relays are used.
- A differential relay is one that operates when the phasor difference of two or more similar electrical quantities exceeds a pre-determined value.
- Thus, a current differential relay is one that compares the current entering a section of the system with the current leaving the section
- There are two fundamental systems of differential or balanced protection viz.

Current balance protection

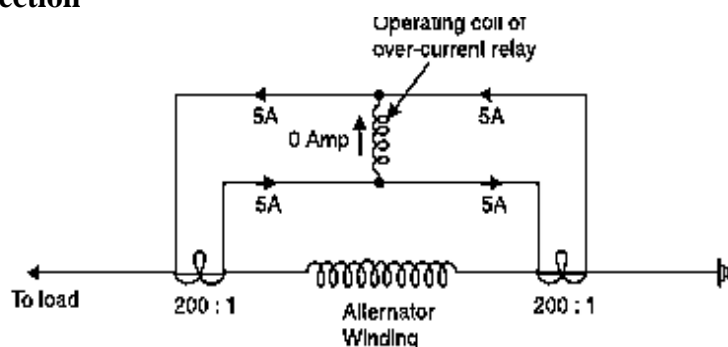

Voltage balance protection

- In this scheme of protection, two similar current transformers are connected at either end of the element to be protected (*e.g.* an alternator winding) by means of pilot wires.
- The secondary of current transformers are connected in series with a relay in such a way that under normal conditions, their induced e.m.f.s' are in opposition.

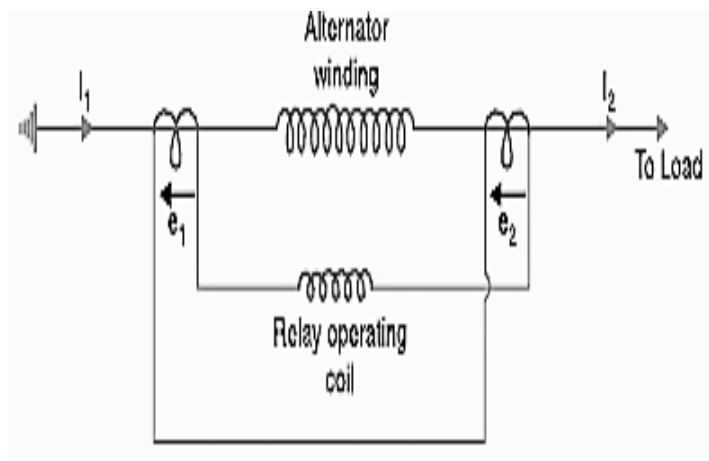

- Under healthy conditions, equal currents ($I_1 = I_2$) flow in both primary windings. Therefore, the secondary voltages of the two transformers are balanced against each other and no current will flow through the relay operating coil.
- When a fault occurs in the protected zone, the currents in the two primaries will differ from one another and their secondary voltages will no longer be in balance.
- This voltage difference will cause a current to flow through the operating coil of the relay which closes the trip circuit.

Disadvantages

- (i) A multi-gap transformer construction is required to achieve the accurate balance between current transformer pairs.
- (ii) The system is suitable for protection of cables of relatively short lengths due to the capacitance of pilot wires. On long cables, the charging current may be sufficient to operate the relay even if a perfect balance of current transformers is attained.

Biased Beam Relay (or) Merze price relay

- The biased beam relay (also called *percentage differential relay*) is designed to respond to the differential current in terms of its fractional relation to the current flowing through the protected section.
- It is essentially an over current balanced beam relay type with an additional restraining coil. The restraining coil produces a bias force in the opposite direction to the operating force.
- Under normal and through load conditions, the bias force due to restraining coil is greater than the operating force.
- Therefore, the relay remains inoperative.
- When an internal fault occurs, the operating force exceeds the bias force. Consequently, the trip contacts are closed to open the circuit breaker. The bias force can be adjusted by varying the number of turns on the restraining coil.

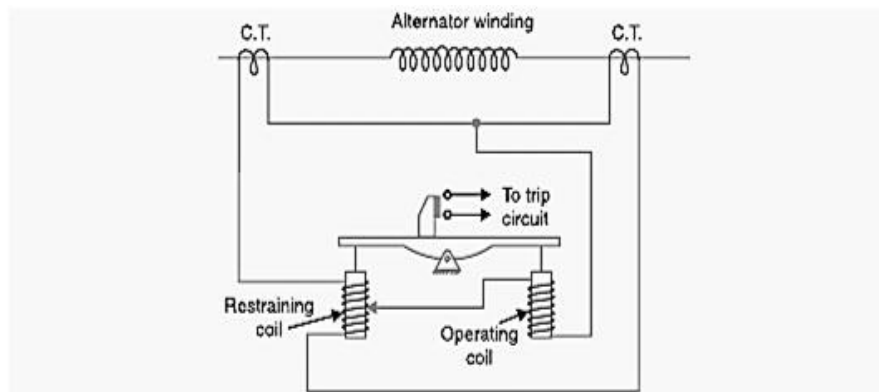



ST ANNES COLLEGE OF ENGINEERING AND TECHNOLOGY
DEPARTMENT OF ELECTRICAL AND ELECTRONICS ENGINEERING
EE8602 PROTECTION AND SWITCHGEAR
UNIT III
APPARATUS PROTECTION

Fault and Abnormal Conditions

- Generator : Over Current, Over Voltage, Under Voltage, Under Frequency, Unbalanced Current, Loss of Excitation, Reverse Power, Winding Inter turn Fault, Winding Earth Fault etc.
- Transformer : Over Current, Winding Inter turn fault, Excessive Temperature Rise, Unbalance Current, Over fluxing etc.
- Motors : Over Current, Under Voltage, Unbalance Current, Winding Short Circuit, Stator Earth Fault, etc.
- Transmission Line : Single Phase to ground fault, Phase to Phase Fault, three phase to ground fault, Over Current etc.

Current and Voltage Transformers in Protective Relaying System

- Protective Relays in A.C. Power Systems are connected from the secondary circuits of C.T. & P.T.
- Current Transformers: C.T. are used for measurement and Protection. Its step down the current from high value to low current value. Their ratio is constant for given range of Primary & Secondary Current.
- Potential Transformer: P.T. are used for measurement and Protection. Its step down the high voltage to low voltage value. The ratio is constant for given range of Primary and Secondary voltage.

Current Transformers

- A device which transforms the current on the power system from large primary values to safe secondary values. The secondary current will be proportional (as per the ratio) to the primary current.

Potential Transformers

- A device which transforms the voltage on the power system from primary values to safe secondary values, in a ratio proportional to the primary value.

Generator Protection

- **Stator**
 - Phase to Phase fault.
 - Inter – turn fault
 - Earth fault (80% & 100%)
- **Rotor**
 - Rotor E/F – Two stage relay: a) Alarm b) Trip
 - Over voltage in the rotor.

ABNORMAL OPERATING CONDITIONS

- Negative Phase sequence
- Loss of Excitation
- Over fluxing protection
- Reverse power
- Over-speeding
- Pole slipping/ Out of Step

PROTECTION CATEGORY

- Complete Generator protection is divided into two category i.e.
- Class – A Protection
- Class – B Protection
- CLASS – A: Protection where electrical isolation is an emergency.(Insulation failure, ,S.C. etc.). Trip the GCB/Turbine/Boiler without time delay or Generator automatic trips.
- Class – A follows;
- Gen. Differential Prot.
- Gen. 100% E/F
- Gen. SB E/F
- Gen. NVD
- Gen. O/C
- Rotor 2nd stage E/F
- Gen. Brg. Temp. high

EARTH FAULT:

- When fault current flows through earth return path, the fault is called Earth Fault.
- Possible causes are ;(a) Insulation failure, (b) due to overheating (Failure of water/air circulation through stator conductor).
- Earth fault may occur between any phase conductor and core.
- It is usually practice to limit the earth fault current to avoid extensive damage to the stator core.

STAND BY EARTH FAULT:

- This protection is practically protecting 95% of generator winding. Therefore, a current setting of 5% of in to be set.
- E/F current is generally limited to about 15/20Amps.
- Earth fault current of even 100A for few seconds can cause external damage. So the earth fault is restricted to 100Amps. By providing NGR of 63.5 ohms at 11KV Voltage Level.
- This is a Back-Up protection.

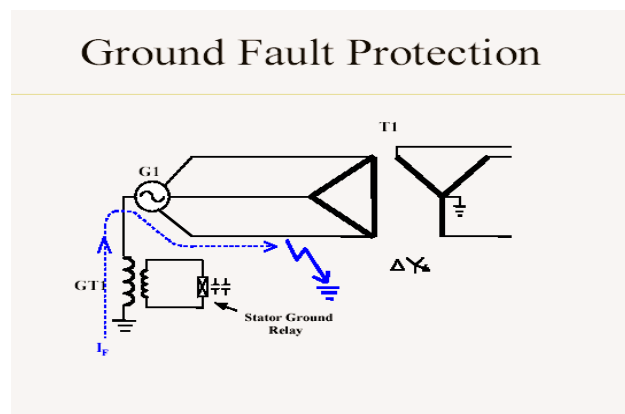

100% STATOR EARTH FAULT

- In this protection, where neutral voltage measurement is made at generator terminals, (By Broken Delta), the third harmonic voltage element is used.
- First earth fault very near to neutral produces negligible current as driving voltage is nearly zero. But if a 2nd earth fault occurs at machine terminal, line to ground fault is not limited by NGR. The resulting fault current can be high. Hence, the 1st E/F very near to neutral has to be detected early and isolated.

- All generators produce continuous current of 3rd harmonic voltage. Under normal condition, 3rd harmonic voltage is present. If there is a fault near neutral, the amount of 3rd harmonic voltage comes down and this is used for detection.
- Since rotor circuits operate ungrounded, a single earth fault is caused by insulation failure due to moisture, ageing of insulation or vibration of rotor etc.
- But existence of single ground fault increases the chance of a second ground fault.
- The occurrence of second earth fault can cause fault current flows.
- This results unsymmetrical flux distribution.
- The air gap flux is badly distorted.
- The rotor is displaced enough to rub stator leading to severe vibrations and can damage the bearing.
- Although a machine can continuously run on a single earth fault but second rotor earth fault, if allowed to occur, should be detected immediately and generator should be tripped.

DIFFERENTIAL PROTECTION

- Differential protection is very reliable method for stator winding phase to phase fault. In this, currents on both sides of the generator are compared.
- Under normal condition or for a fault outside of the protected zone, current i_{1s} is equal to current i_{2s} . Therefore, the currents in the CTs secondaries are also equal, $i_{1s}=i_{2s}$ and no current flows through the current relays.
- If a fault develops inside of the protected zone, current i_{1s} and i_{2s} are no longer equal, therefore i_{1s} and i_{2s} are not equal and therefore a current flowing in the current relay.

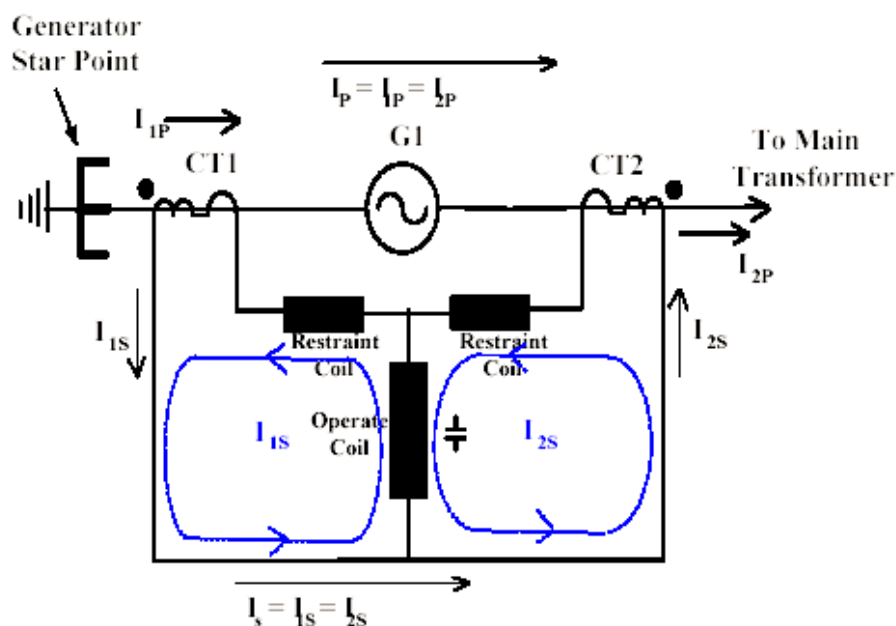

Negative Phase Sequence Protection

- When the generator is connected to a balanced load, the phase currents are equal in magnitude and displaced electrically by 120° . The ATs wave produced by the stator currents rotate synchronously with the rotor and no eddy currents are induced in the rotor parts.
- If there is an unbalanced loading of the generator, and then the stator currents have a -ve sequence component. The stator field due to these -ve sequence currents rotates at synchronous speed but in a direction opposite to the direction of the field structure on the rotor. Thus, the -ve sequence stator armature mmf rotates at a speed $-N_s$, while the rotor field speed is $+N_s$. There is a relative velocity of $2N_s$ between the two.

- These causes double frequency currents, of large amplitude to be induced in the rotor conductors and iron part. So, both the eddy currents as well as the hysteresis losses increase due to these double frequencies induced currents in the rotor.
- Unbalanced loading affects: (a) Rotor heating (b) Severe vibration & heating of stator.

FIELD FAILURE PROTECTION

- Acts as an Induction Generator.
- Possible Causes;
 - AVR Fault
 - Tripping of Field C.B.
 - Open circuit or Short circuit occurring in the D.C. circuit.
 - PMG failure
- In normal condition, generator when running shares, the reactive demand of the system. If excitation fails, synchronous generator runs at a super-synchronous speed, draws reactive power from the power system instead of supplying the Q_e . In case, the other generators can't meet the requirement of reactive power, this shall result in large voltage drop which may ultimately result in instability.
- In this case, slip becomes –Ve result in slip frequency currents. Rotor gets heated up due to induced currents in the rotor winding, core or damage the winding if this condition is sustained. Stator heats up due to high stator currents due to increase in reactive current from the system.

REVERSE POWER PROTECTION

- This protection is provided to protect against motoring.
- A generator is expected to supply active power to the connected system in normal operation. If the generator prime mover fails, a generator that is connected in parallel with another source of electrical supply will to begin to motor. This reversal of power flow due to loss of prime mover can be detected by reverse power element.
- Possible Causes:
 - When immediately after Synchronizing control valves are not operated which may happen due to some fault in the system or some delay by the operating personnel.
 - In case of sudden closure of stop valves or control valves when the generator unit is still connected to the grid.
 - Reverse power operation is harmful to the turbine since without steam flow in the turbine. If the turbine continues to rotate, it will result in heating of turbine blades due to churning action. However, the period for the turbine to overheat may vary from a few seconds to minutes depending upon the turbine & operating conditions.

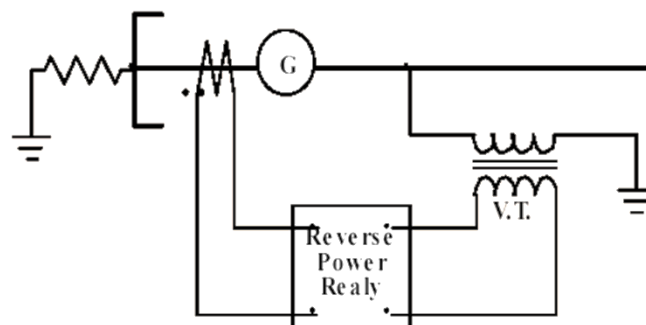

Motor Protection:

- Most of the motor failure contributors and failed motor components are related to motor overheating.
- Thermal stress potentially can cause the failure of all the major motor parts: Stator, Rotor, Bearings, Shaft and Frame.
- Consider a motor is as homogenous body
- Developing heat at constant rate.
- Dissipating heat at constant rate.
- Heat dissipation is proportional to temperature rise

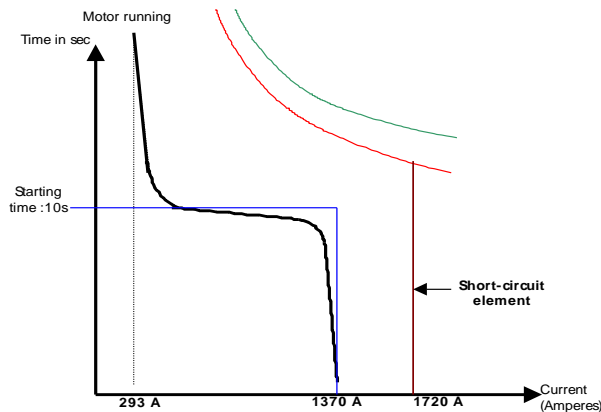

SHORT CIRCUIT PROTECTION

- What is:-Motor short-circuit protection - provided to cater for major stator winding faults and terminal flashovers.
- Settings - Definite time over current relay element, set to about 130% of motor starting current and time delay set at 100ms.

Differential Protection

- Differential protection may be considered the first line of protection for internal phase-to-phase or phase-to-ground faults.

Summation method with six CTs:

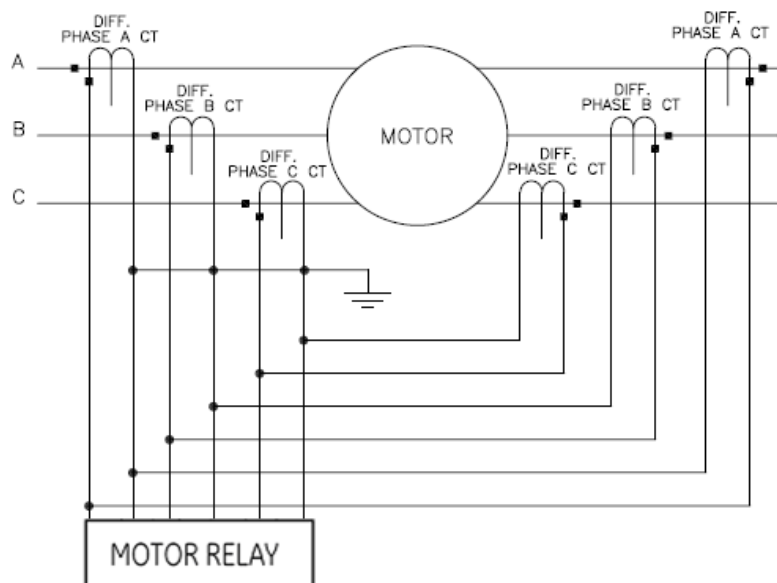

- If six CTs are used in a summing configuration, during motor starting, the values from the two CTs on each phase may not be equal as the CTs are not perfectly identical and asymmetrical currents may cause the CTs on each phase to have different outputs.

- The running differential delay can then be fine tuned to an application such that it responds very fast and is sensitive to low differential current levels.

Ground Fault Protection

- **What is:-**A ground fault is a fault that creates a path for current to flow from one of the phases directly to the neutral through the earth bypassing the load
- **Ground faults in a motor occur:**
 - When its phase conductor's insulation is damaged for example due to voltage stress, moisture or internal fault occurs between the conductor and ground
- **To limit :-**the level of the ground fault current connect an resistance known as stabilising resistance

Protection of Bus bars

Bus Differential: Current into bus must equal current out of bus

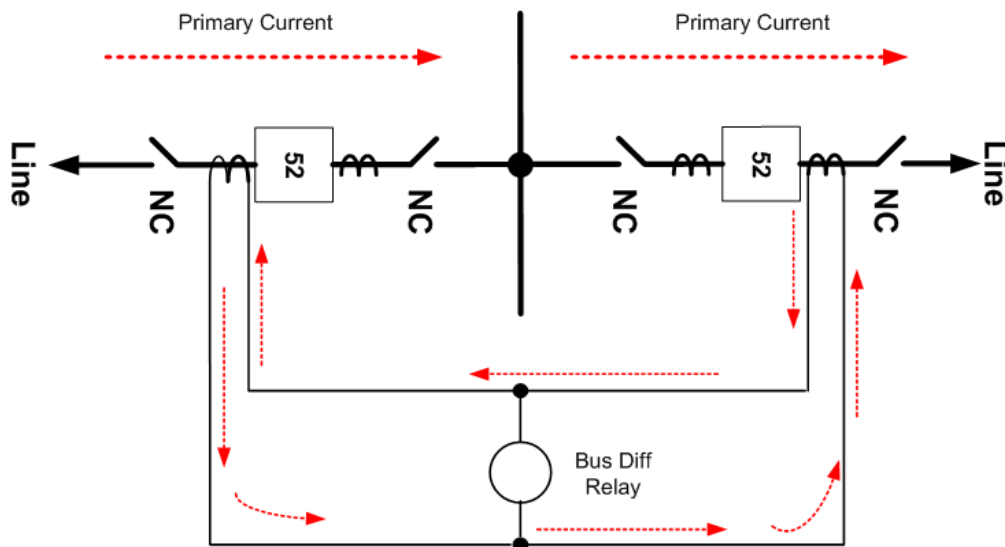

Typical Bus Arrangements:

- Single bus
- Double bus, double breaker
- Breaker-and-a-half
- Main and transfer buses with single breaker
- Ring bus

Bus differential connection (single-bus)

Bus differential connection (single-bus)

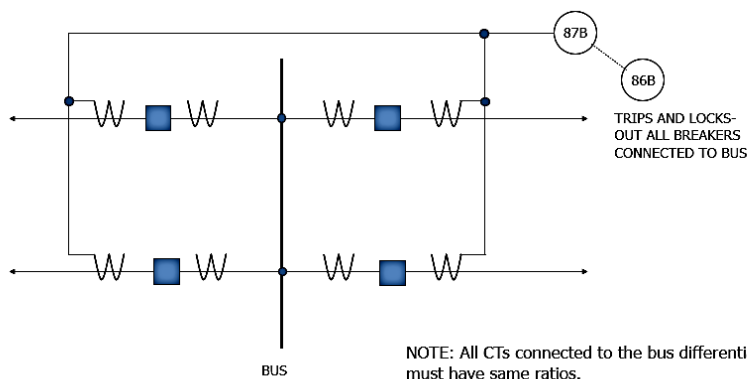

Bus differential connection (double-bus, double-breaker)

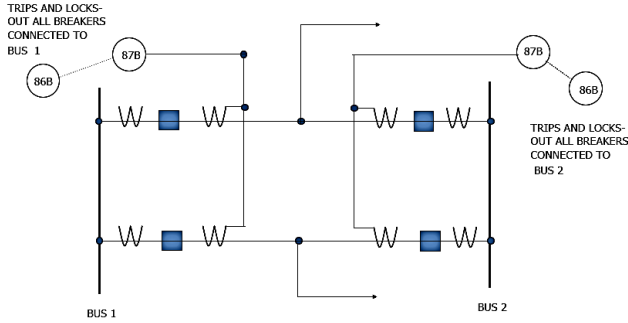

Bus differential connection (breaker-and-a-half)

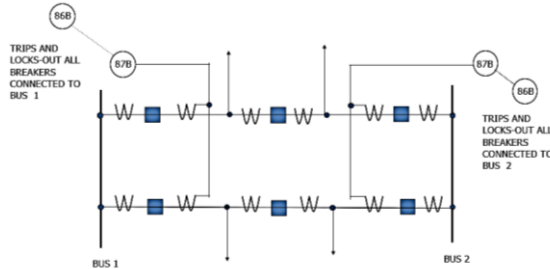

Bus differential connection (main and transfer bus)

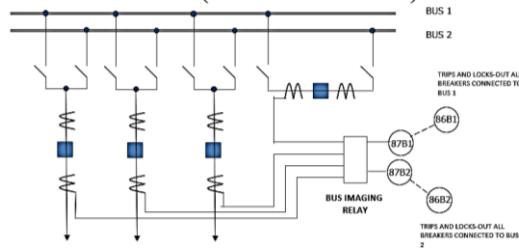

Bus differential connection (ring bus)

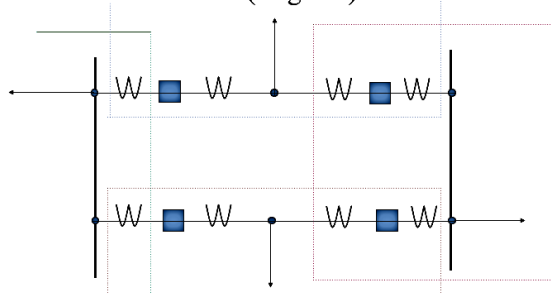

NOTE: No bus differential protection is needed. The busses are covered by line or transformer protection.

Two Busbar Protection Schemes:

- Low Impedance - using time overcurrent relays
 - inexpensive but affected by CT saturation.
 - low voltage application; 34.5kV and below
- High Impedance - using overvoltage relays (this scheme loads the CTs with a high impedance to force the differential current through the CTs instead of the relay operating coil.)
 - expensive but provides higher protection security.
 - 115kV and above voltage application or some 34.5kV bus voltages which require high protection security.

Transmission Line Protection

- Distance Protection
- Over Current Protection
- Differential Protection.
- Main and Back up Protection

Distance Relay Protection

- The basic principle is that the apparent impedance seen by the relay reduces drastically in case of line fault.
- If the ratio of apparent impedance to the positive sequence impedance is less than unity, it indicates a fault.
- This protection scheme is inherently directional.
- Impedance relay and Mho relay use this principle.

Over Current Relay Protection

Principle of Over current Protection

- When the current in a system exceeds a predetermined value, it indicates the presence of a fault.
- Relaying decision is based solely on the magnitude of current.
- Over current relaying and fuse protection uses this principle
- Used in radial distribution systems.

Directional Over Relay Protection

- Directional Over current Protection Uses both magnitude of current and phase angle information for decision making.
- Used in radial distribution systems with source at both ends

Differential Relay Protection for Transmission Line

- By comparing the two currents either in magnitude or in phase or in both, fault can be determined.
- Its implementation requires a communication channel.
- It is extremely accurate.
- Its zone is demarkated by CTs

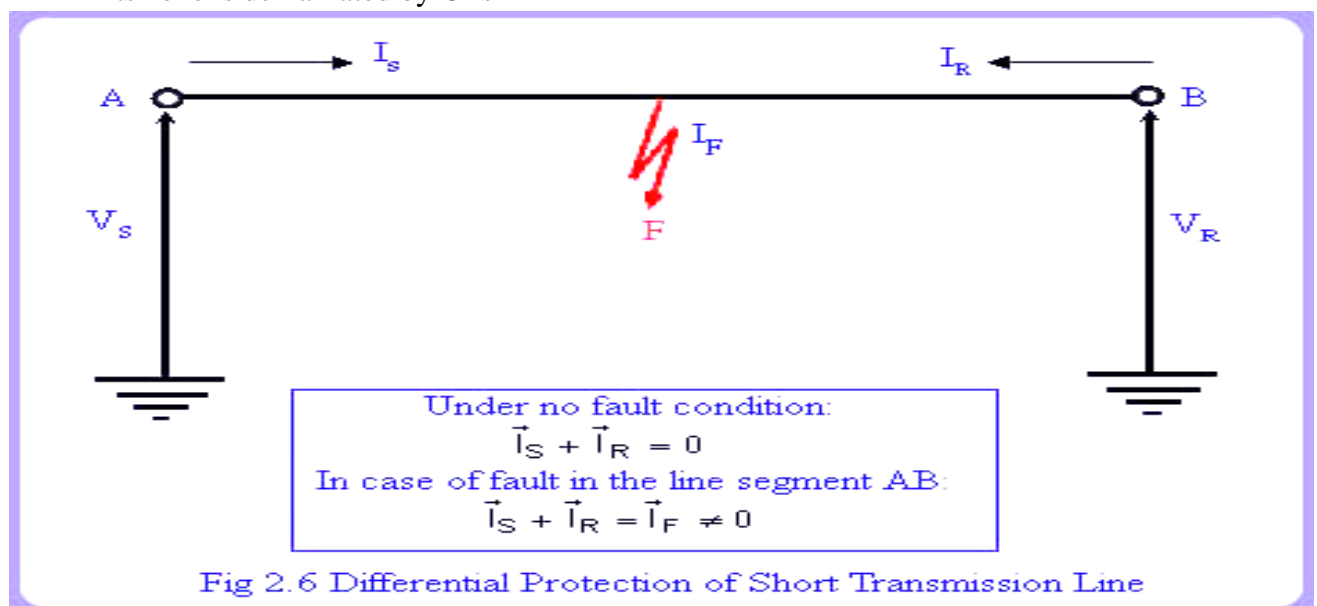

Transformer Protection

Faults occurring in Transformers

- Open-Circuit faults
- Earth faults
- Phase-to-Phase faults
- Inter-Turn faults
- Overheating

Factors in choosing Protective Gear for a Transformer

- Type of Transformer
- Size of the Transformer
- Type of Cooling
- System where used
- Importance of service for which it is required

Transformer Relaying Scheme

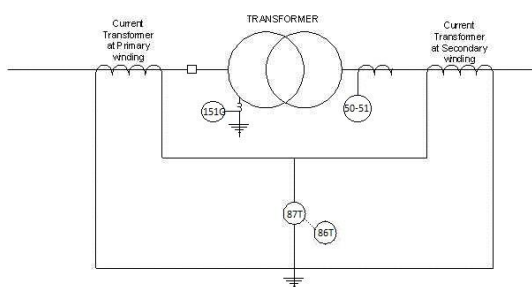

Buchholz Protection

Also known as gas accumulator relay, commonly used on all oil-immersed transformer provided with conservator.

Working Principle:

Whenever a fault occur inside the transformer, the oil of the tank gets overheated and gases are generated. The heat generated by the high local current causes the transformer oil to decompose and produce gas which can be used to detect the winding faults

Core-Balance Leakage Protection

This system is used to provide protection against earth faults on high voltage winding. When earth fault occurs, the sum of the three currents is no longer zero and a current is induced in the secondary of the CT causing the trip relay to operate and isolate the transformer from the bus-bars.

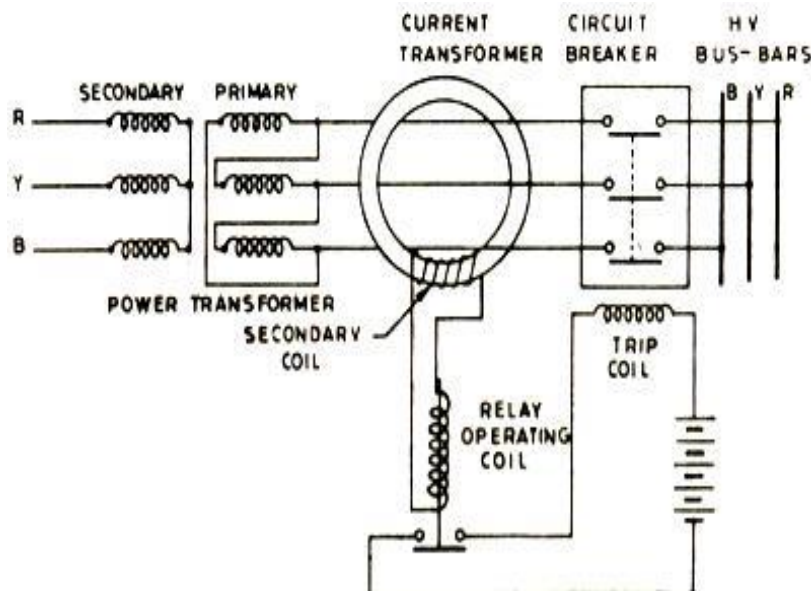

Combined Leakage and Overload Protection

- The core-balance protection cannot provide protection against overload. It is usual practice to provide combined leakage and overload protection for transformer. The earth relay has low current setting and operates under earth faults only. The overload relays have high current setting and are arranged to operate against faults between the phases.
- In this system, two overload relays and one earth relay are connected. The two overload relays are sufficient to protect against phase to phase faults. The trip contacts of overload relays and earth fault relay are connected in parallel. Therefore the energizing of either one of them, the circuit breaker will trip.

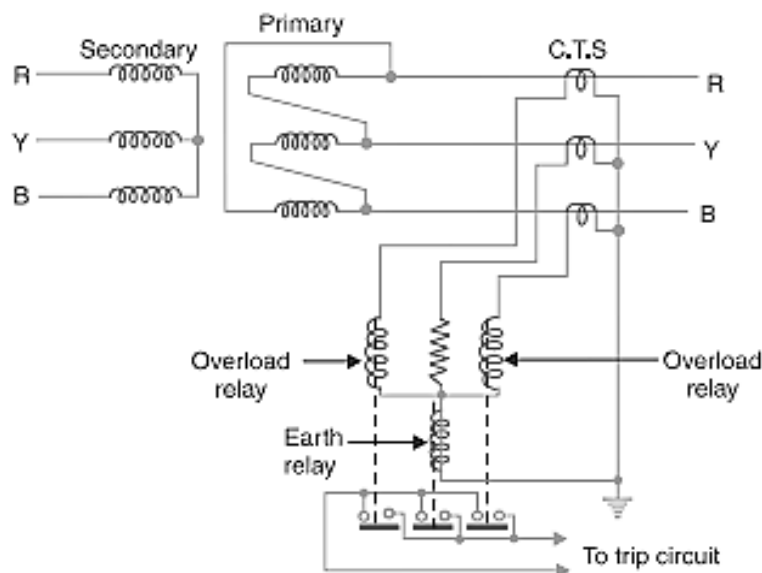

Transformer Protection

☐ Overheating

Normal maximum working temp. = 95 °C

8-10 °C rise will halve the life of the transformer.

☐ Overcurrent

Fuses for distribution transformer

Overcurrent relaying for 5MVA and above

Characteristics:

- Must be below the damage curve
- Must be above magnetizing inrush



ST ANNES COLLEGE OF ENGINEERING AND TECHNOLOGY
DEPARTMENT OF ELECTRICAL AND ELECTRONICS ENGINEERING
EE8602 PROTECTION AND SWITCHGEAR
UNIT IV
STATIC RELAYS AND NUMERICAL PROTECTION

Static Relay

- The static relay is the next generation relay after electromechanical type.
- The Solid Static relays was first introduced in 1960's. The term 'static' implies that the relay has no moving mechanical parts in it.
- Compared to the Electromechanical Relay, the Solid Static relay has longer life-span, decreased noise when operates and faster respond speed.
- The static relays have been designed to replace almost all the functions which were being achieved earlier by electromechanical relays.

Principle of operation

- The essential components of static relays are shown in figure below. The output of CT and PT are not suitable for static components so they are brought down to suitable level by auxiliary CT and PT. Then auxiliary CT output is given to rectifier.
- Rectifier rectifies the relaying quantity i.e., the output from a CT or PT or a Transducer.
- The rectified output is supplied to a measuring unit comprising of comparators, level detectors, filters, logic circuits.
- The output is actuated when the dynamic input (i.e., the relaying quantity) attains the threshold value. This output of the measuring unit is amplified by amplifier and fed to the output unit device, which is usually an electromagnetic one.
- The output unit energizes the trip coil only when relay operates.

Advantages of Solid-State Relay

- Low Weight
- Arc less switching
- Static Relay burden is less than electromagnetic type of relays. Hence error is less.
- Fast response.
- Long life
- Less power consumption
- More Accurate compared to electromechanical Relay

Disadvantages

1. Reliability cannot be predicted
2. Construction is not very robust.
3. Easily affected by surrounding interference.
4. Auxiliary DC supply is required
5. Affected by voltage transients.

Applications

1. Ultra high speed protection of EHV AC transmission lines utilizing distance protection.
2. In over current and earth fault protection schemes
3. As main element in differential relay

NUMERICAL RELAY

- Speed
- Sensitivity
- Reliability
- Selectivity
- Simplicity
- Economy

Advantages of numerical relay

- Flexibility in wide parameter adjustment.
- Programmable function setting
- Multiple functions by the same relay
- Internal fault diagnosis.
- Memory & recording function
- Programmable CT & PT ratio
- Digitally communication facility

Disadvantages of numerical relays

- High initial cost
- Requires stable power supply.
- If used for multifunction in a single feeder, failure of relay may cause total protection failure for the equipment.
- Requires emc environment.

Applications:

- Control a high-voltage circuit with a low-voltage signal, as in some types of modems or audio amplifiers,
- Control a high-current circuit with a low-current signal, as in the starter solenoid of an automobile
- Detect and isolate faults on transmission and distribution lines by opening and closing circuit breakers (protection relays)

Numerical Relay Protection of Transformer

- Transformers are a critical and expensive component of the power system. Due to the long lead time for repair and replacement of transformers, a major goal of transformer protection is limiting the damage to a faulted transformer.
- Numerical relay protection of transformer is an advanced method of protection.
- The main aim of this project is to protect the transformer from the faulty conditions within a short span of time.
- The type of protection for the transformers varies depending on the application of the transformer.

DIFFERENTIAL PROTECTION:

- Differential protection is a unit-type protection for a specified zone or piece of equipment. It is based on the fact that it is only in the case of faults internal to the zone that the differential current (difference between input and output currents) will be high. However, the differential current can sometimes be substantial even without an internal fault. This is due to certain

characteristics of current transformers (different saturation levels, nonlinearities) measuring the input and output currents, and of the power transformer being protected.

- It is based on the fact that any fault within an electrical equipment would cause the current entering it to be different from the current leaving it.
- By comparing the two currents either in magnitude or in phase or in both, fault can be determined.

NEED FOR PROTECTION

- Transformer is an extreme device in power system which has 99.99% of efficiency. Improved power transformer protection using numerical relays, Large power transformers belong to a class of very expensive and vital components in electric power systems.
- If a power transformer experiences a fault, it is necessary to take the transformer out of service as soon as possible so that the damage is minimized.
- The costs associated with repairing a damaged transformer may be very high. So there is a necessity of protection of transformer.
- Fault detection and correction is necessary for the safe operation of transformer.
- Protection of large power transformers is perhaps the most challenging problem in the power system relaying.
- Here we are using numerical relay for the protection of Power Transformer.

OVER LOADING PROTECTION:

- Initially the transformer is operated under normal condition the relay operation is absent.
- The transformer has a maximum safe current rating value for certain load, if the load is increased on the transformer then the load current is also increased.
- If the load current exceeds the maximum rated current of the transformer then the relay will operate and the transformer is isolate from the main supply.

DIFFERENTIAL PROTECTION:

- At normal operating condition the differential currents of CTs is zero. So here in this case the differential relay will not operate. As we know that the differential relay is operate only for internal fault condition.
- If the fault occurred in internal zone(between transformer and CTs) then a differential current flows in the relay, the relay is tripped and isolate the transformer from the mains.

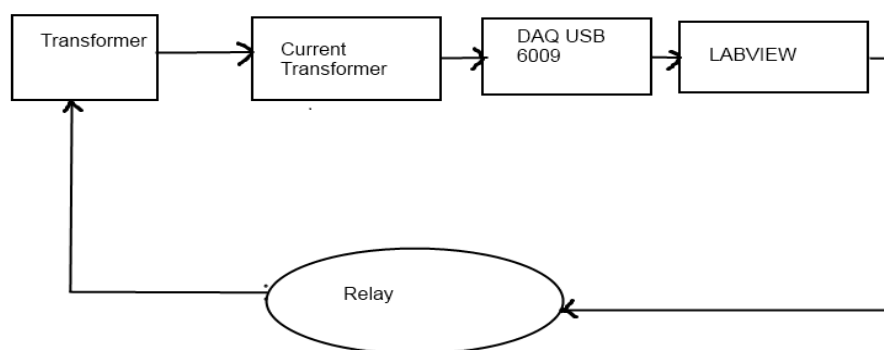

COMPONENTS USED:

- Potential transformer(24/230v, 1A)
- Current transformer
- Auto transformer (0 to 270v)
- Data acquisition (DAQ USB-6009)
- Resistive load (15w bulb -2, 60w bulb -1)

ADVANTAGES:

1. It is the simplest form of transformer protection.
2. It detects the incipient faults at a stage much earlier than is possible with other forms of protection.

DISADVANTAGES:

1. It can only be the used with oil immersed transformer equipped with conservator tanks.
2. The device can detect only faults below oil level in the transformer. Therefore, separate protection is needed for connecting cables.



The Arc:

The electric arc constitute a basic ,indispensable and active element in the process of current interruption.

1.Basic theory of electric discharge

The conduction of electricity is through the gases or vapors which contain positive and negative charge carriers and all types of discharge involve the very fundamental process of production , movement & absorption of these carriers which is the mode of carrying the current between the electrodes. The gas discharge phenomena can broadly classified as:

- a. The non-self sustained discharge
- b. The self sustaining discharges

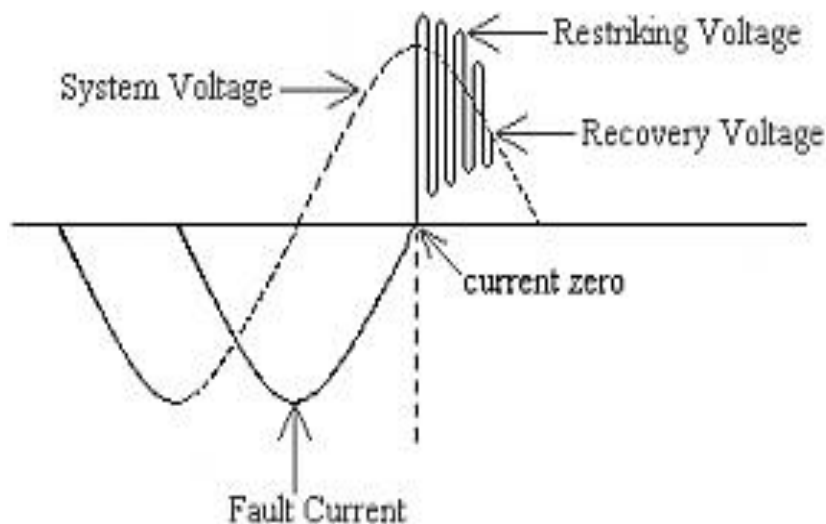

Initiation of an Arc

- By high voltage gradient at the cathode resulting into field emission.
- By increase of temperature resulting into thermo ionic emission

Maintenance of Arc

- High temperature of the medium around the contacts caused by high current densities, with high temp the kinetic energy gained by moving electrons increased.
- The field strength or volt. gradient which increases the kinetic energy of the moving electrons and increases the chances of detaching electrons from neutral molecule.
- An increase in mean free path-the distance through which the electron moves freely.

Methods of Arc Extinction

- High resistance method
 - a. cooling of arc
 - b. increasing the arc length
 - c. reducing the cross section of arc
 - d. splitting of arc
- Low resistance or current zero interruption
 - a. Lengthening of the gap
 - b. increasing the pressure in the vicinity of the arc
 - c. Cooling
 - d. Blast Effect

Phenomenon of arc extinction

■ Energy Balance or Cassie Theory

This theory states that if the rate of heat dissipation between the contacts is greater than the rate at which heat is generated, the arc will be extinguished, otherwise it will restrike.

■ Recovery rate or Slepian's Theory

This theory states that if the rate at which the ions and electrons combine to form or replaced by neutral molecules.

Restriking Voltage & Recovery Voltage

- The transient voltage which appears across the breaker contacts at the instant of arc being extinguished is known as restriking voltage.
- The power frequency rms voltage, which appears across the breaker contacts after the arc is finally extinguished and transient oscillation die out is called recovery voltage.

Arc Quenching: (C.B)

- The Arc Produced not only delays the current interruption process but it also generates enormous heat which may cause damage to the system or to the circuit breaker itself.
- Therefore main problem in a C.B is to extinguish the arc within the shortest possible time so the heat generated by it may not reach a dangerous value.

Arc Phenomenon:

- During arcing period, the current flowing between the contacts depends upon the resistance.
- The greater resistance smaller the current that flows between the contacts.
- The arc resistance depends upon
 - i) Degree of ionisation (Arc resistance increases with the decrease in number of ionised particles b/w the contact)
 - ii) Length of Arc (Arc resistance increases with the length of arc)
- iii) Cross section of Arc (Arc resistance increases with the decrease in X- section of the arc)
- The factors that are responsible for maintenance of arc between the contacts are:
 - i) Potential Difference between the contacts.
 - ii) Ionized particles between the contacts.

Methods of Arc Interruption

- There are two methods of Arc Interruption or Extinction are
 - i) High resistance interruption
 - ii) Current zero interruption

High resistance interruption

The arc resistance can be increased by cooling, lengthening, reducing x- section and splitting the arc. It is employed for low power AC and DC circuit breakers.

Current zero interruption

There are two theories to explain the zero current interruption of the arc.

- i) Recovery rate theory(Slepain's Theory)
- ii) Energy balance theory(Cassie's Theory)

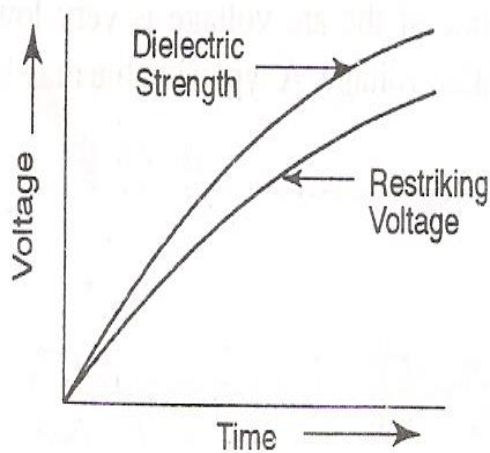

(a) Arc extinguishes

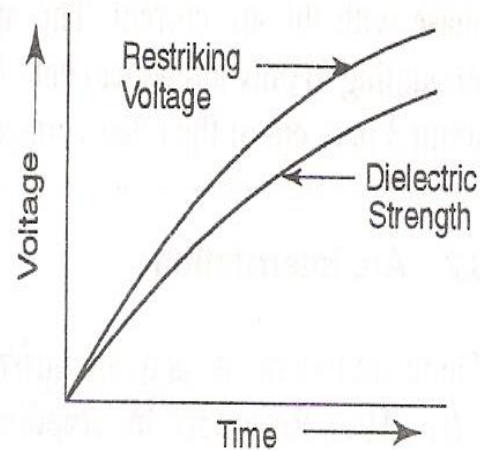

(b) Arc does not extinguishes

Arc Extinction in oil Circuit Breaker

In case of oil circuit breaker the opening of contact which heats the oil surrounds the contact due to arc which causes hydrogen gas bubble to evolve and its removes the heat from the surface. If the rate of heat removal is faster than its generation then the arc is extinguished.

Splitting the Arc:

In this method the arc is elongated and splitted by arc splitters. These are made with plates of resin bonded fiber gas. These are placed perpendicular to arc and arc is pulled into them by electromagnetic forces.

Circuit breakers:

A circuit breaker is an automatically operated electrical switch designed to protect and electrical circuit from damage caused by overload or short circuit.

Air-Blast Circuit Breakers

In this air is compressed to high pressures

Types

Depending upon the direction of air blast in relation to the arc,

- i. Axial blast type in which air-blast is directed along the arc path

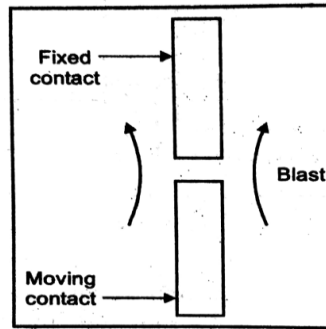

- ii. Cross-blast type in which air blast is directed at right angles to the arc path.

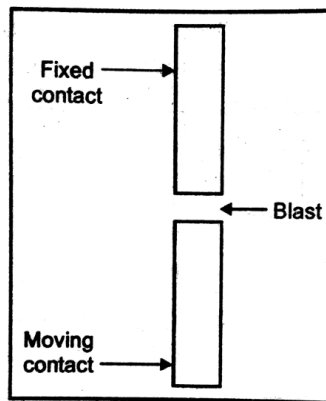

- iii. Radial-blast type in which the air blast is directed radially

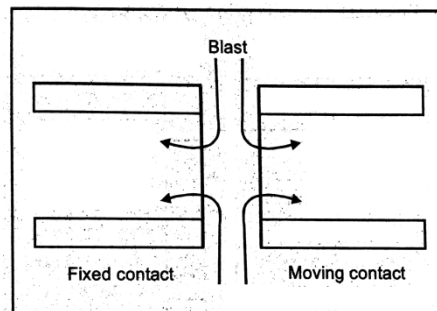

1. Axial-blast air circuit breaker

- The essential components of a typical axial blast circuit breaker is the fixed and moving contacts are held in closed position by spring pressure under normal conditions.
- The air reservoir is connected to the arcing chamber through an air valve.
- This valve remains closed under normal conditions but opens automatically by tripping when a fault occurs on the system
- When a fault occurs the tripping impulse causes the opening of the air valve which connects the circuit breaker reservoir to the arcing chamber.
- The high pressure air entering the arcing chamber pushes away the moving contact against spring pressure.
- The moving contact is separated and an arc is struck
- At the same time, high pressure air blast flows along the arc and takes away the ionized gases along with it. Consequently, the arc is extinguished and current flow is interrupted.

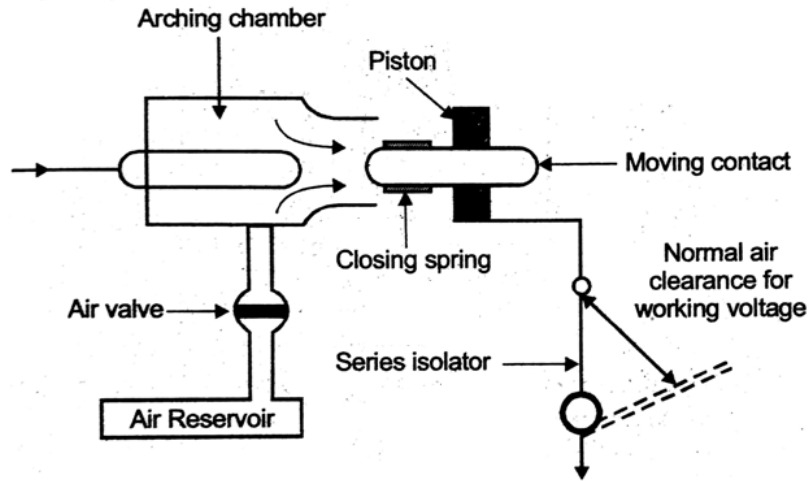

2. Cross blast air breaker

- An air blast is directed at right angles to the arc.
- The cross-blast lengthens and forces the arc into a suitable chute for arc extinction.
- When the moving contact is withdrawn, arc is struck between the fixed and moving contacts and the high pressure cross-blast forces into a chute of an arc splitters and baffles.

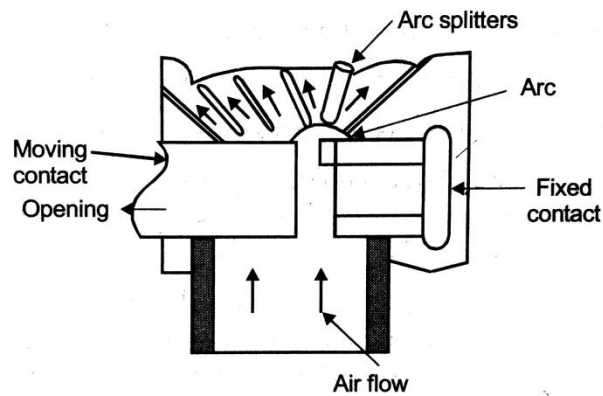

- The splitters serve to increase the length of the arc and baffles give improved cooling.
- The result is that arc is extinguished and flow of current is interrupted.

SF₆ CIRCUIT BREAKERS

- It contains an arc interruption chamber containing SF₆ gas.
- In closed position the contacts remain surrounded by SF₆ gas at a pressure of 2.8 kg/cm².

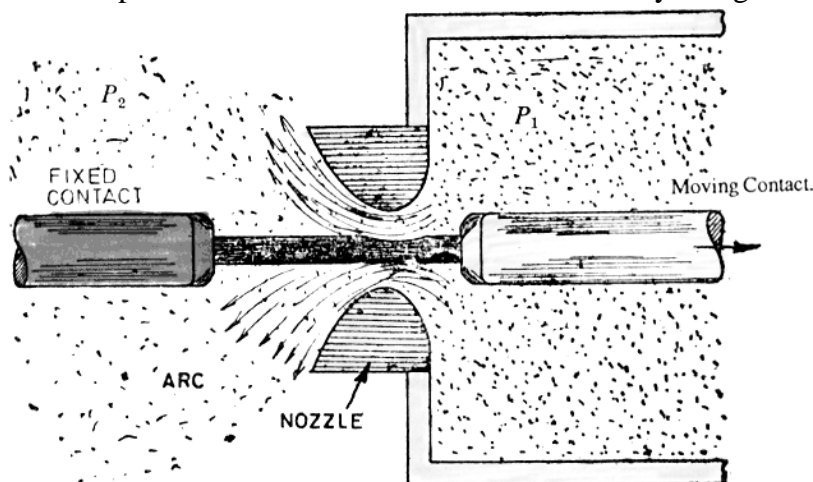

(a) Arc extinction in gas flow circuit-breakers (Gas flow from high pressure P_1 to low pressure P_2 via an insulating nozzle)

- During opening high pressure SF₆ gas at 14 kg/cm² from its reservoir flows towards the chamber by valve mechanism.
- SF₆ rapidly absorbs the free electrons in the arc path to form immobile negative ions to build up high dielectric strength.
- It also cools the arc and extinguishes it.
- After operation the valve is closed by the action of a set of springs.
- Absorbent materials are used to absorb the byproducts and moisture.

Advantages:

- Very short arcing period due to superior arc quenching property of SF₆.
- Can interrupt much larger currents as compared to other breakers.
- No risk of fire.
- Low maintenance, light foundation.
- No over voltage problem.
- There are no carbon deposits.

Disadvantages:

- SF₆ breakers are costly due to high cost of SF₆.
- SF₆ gas has to be reconditioned after every operation of the breaker, additional equipment is required for this purpose.

VACUUM CIRCUIT BREAKER

- It is designed for medium voltage range (3.3-33kv).
- This consists of vacuum of pressure (1×10^{-6}) inside arc extinction chamber.
- The arc burns in metal vapour when the contacts are disconnected.
- At high voltage, its rate of dielectric strength recovery is very high.
- Due to vacuum arc extinction is very fast.
- The contacts loose metals gradually due to formation of metal vapours.

OIL CIRCUIT BREAKER

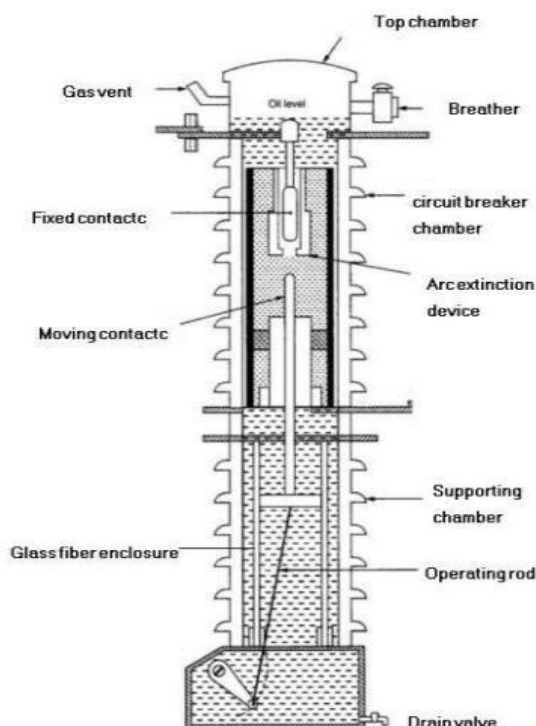

- It is designed for 11kv-765kv.
- These are of two types
 - BOCB (Bulk oil Circuit Breaker)
 - MOCB (Minimum oil Circuit Breaker)
- The contacts are immersed in oil bath.
- Oil provides cooling by hydrogen created by arc.
- It acts as a good dielectric medium and quenches the arc.

Advantages:

- Oil has good dielectric strength.
- Low cost.
- Oil is easily available.
- It has wide range of breaking capability.

Disadvantages:

- Slower operation, takes about 20 cycles for arc quenching.
- It is highly inflammable, so high risk of fire.
- High maintenance cost.